

**LEAD COLORS**

1 = BROWN  
2 = BLUE

SPECIFICATIONS	
HOUSING MATERIAL/FINISH	BRASS/NICKEL
RATED VOLTAGE [V]	600 V
OUTER JACKET MATERIAL/COLOR	PVC/BLACK
INNER JACKET MATERIAL/COLOR	PVC/BLACK
CONDUCTOR INSULATION MATERIAL	PVC
NUMBER OF CONDUCTORS	2x18 AWG
ARMOR	CONTINUOUS, CORRUGATED ALUMINUM ARMOR
TEMPERATURE RATING	-40°C to +80°C (-40°F to +176°F)
CABLE RATING	UL: MC-HL, DIRECT BURIAL, 90C CSA: ACIC-HL, 90C, 600V

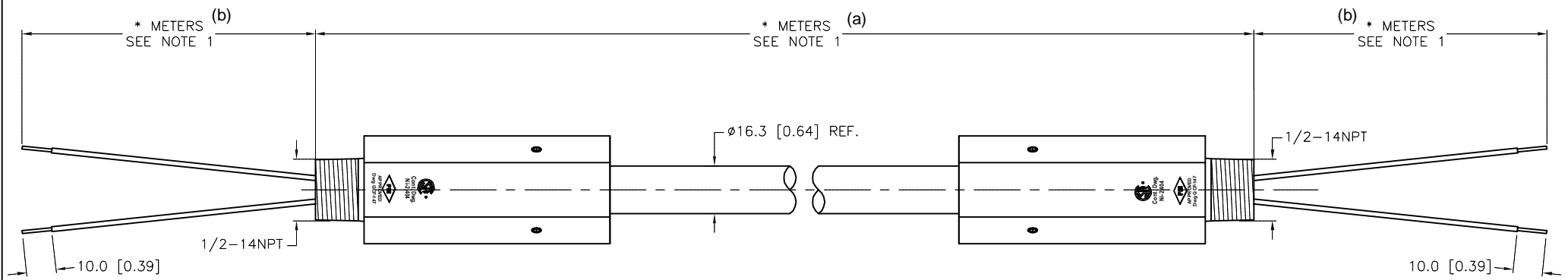

CABLE LENGTH	TOLERANCE*
ALL LENGTHS	+ 4% (OR 50mm) OF LENGTH - 0% (OR 0mm) OF LENGTH WHICHEVER IS GREATER
STRIP LENGTH	TOLERANCE*
0-7mm	±0.5mm
8-29mm	±1.0mm
30-49mm	±2.0mm
50-69mm	±3.0mm
70-100mm	±4.0mm
OVER 100mm	±5.0mm

\* UNLESS OTHERWISE SPECIFIED

NOTES:  
1. "\*" INDICATES CABLE LENGTH IN METERS. CONTACT TURCK TO ORDER SPECIFIC LENGTHS.

SOURCE DRAWING - FOR REFERENCE ONLY

RELATED DOCUMENTS 1. 2. 3. 4.	3RD ANGLE PROJECTION 	THIS DRAWING IS CONFIDENTIAL AND THE PROPERTY OF TURCK INC. USE OF THIS DOCUMENT WITHOUT WRITTEN PERMISSION IS PROHIBITED.		3000 CAMPUS DRIVE MINNEAPOLIS, MN 55441 1-800-544-7769 (763) 553-7300 (763) 553-0708 fax www.turck.us	
		MATERIAL  SEE SPECIFICATIONS	DRFT RDS APVD J.S.	DATE 02/05/14 SCALE 1=2.0	DESCRIPTION P-EXG2-2032-*/*/14.5/NPT/UNION (a) (b)
FINISH  SEE SPECIFICATIONS	ALL DIMENSIONS DISPLAYED ON THIS DRAWING ARE FOR REFERENCE ONLY  CONTACT TURCK FOR MORE INFORMATION	UNIT OF MEASUREMENT <b>MILLIMETER [ INCH ]</b>		IDENTIFICATION NO.	
DO NOT SCALE THIS DRAWING		FILE: 777032889		REV D	

D	UPDATE TEMP SPECS	RDS	11/09/18	65817
REV	DESCRIPTION	BY	DATE	ECO NO.